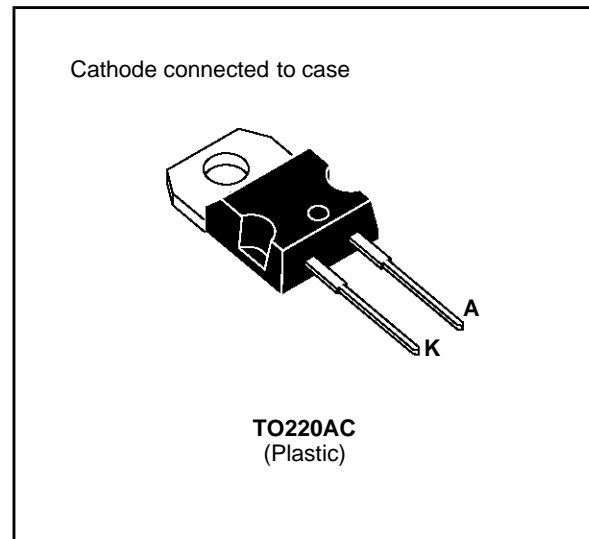

**FAST RECOVERY RECTIFIER DIODE**

- VERY HIGH REVERSE VOLTAGE CAPABILITY
- VERY LOW REVERSES RECOVERY TIME
- VERY LOW SWITCHING LOSSES
- LOW NOISE TURN-OFF SWITCHING

**SUITABLE APPLICATIONS**

- FREE WHEELING DIODE IN CONVERTERS AND MOTOR CONTROL CIRCUITS
- RECTIFIER IN S.M.P.S.

**ABSOLUTE RATINGS** (limiting values)

Symbol	Parameter		Value	Unit
$V_{RRM}$	Repetitive Peak Reverse Voltage		1000	V
$V_{RSM}$	Non Repetitive Peak Reverse Voltage		1000	V
$I_{FRM}$	Repetitive Peak Forward Current	$t_p \leq 10\mu s$	100	A
$I_F (RMS)$	RMS Forward Current		16	A
$I_F (AV)$	Average Forward Current	$T_c = 115^\circ C$ $\delta = 0.5$	8	A
$I_{FSM}$	Surge Non Repetitive Forward Current	$t_p = 10ms$ Sinusoidal	50	A
P	Power Dissipation	$T_c = 115^\circ C$	17	W
$T_{stg}$ $T_j$	Storage and Junction Temperature Range		- 40 to + 150 - 40 to + 150	$^\circ C$

**THERMAL RESISTANCE**

Symbol	Parameter	Value	Unit
$R_{th(j-c)}$	Junction-case	2	$^\circ C/W$

**ELECTRICAL CHARACTERISTICS**

**STATIC CHARACTERISTICS**

Symbol	Test Conditions		Min.	Typ.	Max.	Unit
I <sub>R</sub>	T <sub>j</sub> = 25°C	V <sub>R</sub> = V <sub>RRM</sub>			35	μA
	T <sub>j</sub> = 100°C				2	mA
V <sub>F</sub>	T <sub>j</sub> = 25°C	I <sub>F</sub> = 8A			1.9	V
	T <sub>j</sub> = 100°C				1.8	

**RECOVERY CHARACTERISTICS**

Symbol	Test Conditions			Min.	Typ.	Max.	Unit
t <sub>rr</sub>	T <sub>j</sub> = 25°C	I <sub>F</sub> = 1A	di <sub>F</sub> /dt = - 15A/μs			155	ns
		I <sub>F</sub> = 0.5A	I <sub>R</sub> = 1A			I <sub>rr</sub> = 0.25A	

**TURN-OFF SWITCHING CHARACTERISTICS (Without Series Inductance)**

Symbol	Test Conditions		Min.	Typ.	Max.	Unit
t <sub>IRM</sub>	di <sub>F</sub> /dt = - 32A/μs	V <sub>CC</sub> = 200 V I <sub>F</sub> = 8A L <sub>p</sub> ≤ 0.05μH T <sub>j</sub> = 100°C See Figure 1			200	ns
	di <sub>F</sub> /dt = - 64A/μs			120		
I <sub>RM</sub>	di <sub>F</sub> /dt = - 32A/μs				5.5	A
	di <sub>F</sub> /dt = - 64A/μs			6		

**TURN-OFF OVERVOLTAGE COEFFICIENT (With Series Inductance)**

Symbol	Test Conditions			Min.	Typ.	Max.	Unit
$C = \frac{V_{RP}}{V_{CC}}$	T <sub>j</sub> = 100°C	V <sub>CC</sub> = 200V	I <sub>F</sub> = I <sub>F(AV)</sub>			4.5	
	di <sub>F</sub> /dt = - 8A/μs	L <sub>p</sub> = 12μH	See figure 2				

To evaluate the conduction losses use the following equations:  
 $V_F = 1.47 + 0.041 I_F$        $P = 1.47 \times I_{F(AV)} + 0.041 I_F^2_{(RMS)}$

Figure 1. Turn-off switching characteristics (without series inductance).

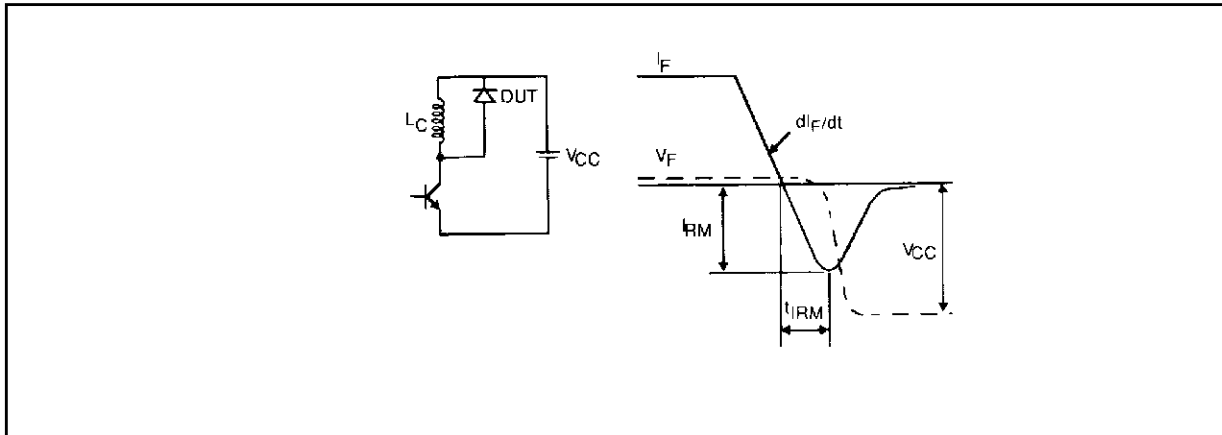
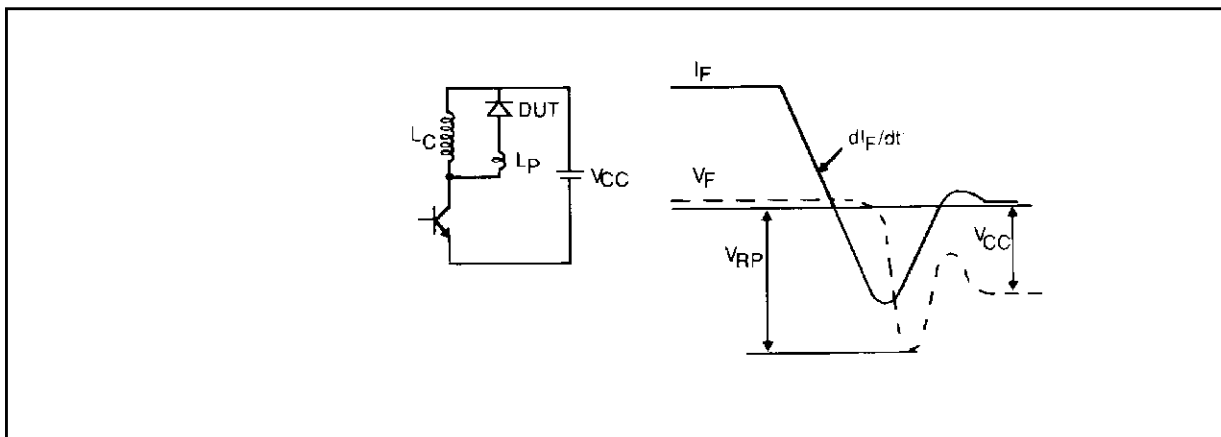
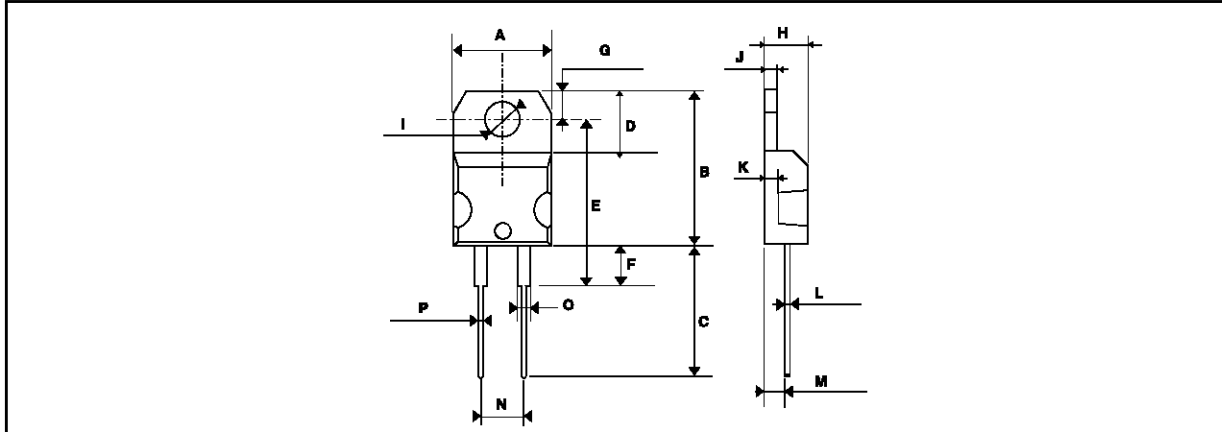

Figure 2. Turn-off switching characteristics (with series inductance).



PACKAGE MECHANICAL DATA : TO220AC Plastic



REF.	DIMENSIONS			
	Millimeters		Inches	
	Min.	Max.	Min.	Max.
A	10.0	10.4	0.393	0.409
B	15.2	15.9	0.598	0.626
C	13	14	0.511	0.551
D	6.2	6.6	0.244	0.260
E	16.4 typ.		0.645 typ.	
F	3.5	4.2	0.137	0.165
G	2.65	2.95	0.104	0.116
H	4.4	4.6	0.173	0.181
I	3.75	3.85	0.147	0.151
J	1.23	1.32	0.048	0.051
K	1.27 typ.		0.050 typ.	
L	0.49	0.70	0.019	0.027
M	2.4	2.72	0.094	0.107
N	4.95	5.15	0.194	0.203
O	1.14	1.70	0.044	0.067
P	0.61	0.88	0.024	0.034

Cooling method: by conduction (method C)  
 Marking: type number  
 Weight: 2.42g  
 Recommended torque value: 80cm. N  
 Maximum torque value: 100cm. N

Information furnished is believed to be accurate and reliable. However, SGS-THOMSON Microelectronics assumes no responsibility for the consequences of use of such information nor for any infringement of patents or other rights of third parties which may result from its use. No license is granted by implication or otherwise under any patent or patent rights of SGS-THOMSON Microelectronics. Specifications mentioned in this publication are subject to change without notice. This publication supersedes and replaces all information previously supplied. SGS-THOMSON Microelectronics products are not authorized for use as critical components in life support devices or systems without express written approval of SGS-THOMSON Microelectronics.

© 1994 SGS-THOMSON Microelectronics - Printed in Italy - All rights reserved.

SGS-THOMSON Microelectronics GROUP OF COMPANIES  
 Australia - Brazil - France - Germany - Hong Kong - Italy - Japan - Korea - Malaysia - Malta - Morocco - The Netherlands  
 Singapore - Spain - Sweden - Switzerland - Taiwan - United Kingdom - U.S.A.